

# ISA2020VGBC1CKA1

◆ Outline (L\* W\*H): 2.0\*2.0\*0.75mm

◆ Good thermal dissipation & optical uniformity

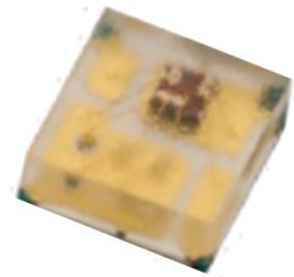

## Table of Contents

Product Code Method-----	2
Maximum Rating-----	2
Typical Product Characteristics-----	3
Range of Bins-----	3
Color Coordinate Comparison-----	4
Electrical Characteristics -----	5
Switching Characteristics -----	5
Data transfer time -----	6
Dimensions -----	7
PIN Configuration -----	8
Reflow Profile -----	9
Test Circuit and Handling Precautions -----	10
Packing-----	11-12
Precautions-----	13
Test Items and Results of Reliability-----	14

## Features

- RoHS2.0 Compliant
- Packaged in 12mm tape on 7" diameter reels
- EIA STD package
- Compatible with automatic placement equipment and infrared reflow solder process
- Preconditioning: accelerate to JEDEC level 3
- RGB and driver chip are integrated in a package, to form a complete control of pixel point with constant current.
- One pixel contains R, G, and B color that each can achieve 256 level brightness grayscale, which forms 16, 777, 216 combination colors. Internal clock frequency operates at 800 kHz.
- Serial data transmission signal by single wire.

## Applications

- Telecommunication, office automation, home appliances, industrial equipment
- Status indicator
- Signal and symbol luminaire
- Front panel backlighting
- Full-color strip.
- Indoor decorative lighting / curtain display

**Product Code Method**
**I - S - A - 2020 - VGBC - 1 - C - K - A1**

①    ②    ③    ④    ⑤    ⑥    ⑦    ⑧    ⑨

①	②	③	④	⑤
Process Type	Category	LED Type	Lead Frame Size	Dice wavelength & luminous rank
I: With IC Series	S: SMD LED	A: PCB top view	2020: 2.0*2.0mm	V:red G:green B:blue C:IC

⑥	⑦	⑧	⑨
Lap Polarity	Cap Color	PCB Module Code	Flow Code
1: common anode	C: water transparent	K: article mode	A: IC Type 104 1: SMA

**Maximum Rating(Ta=25°C)**

Parameter	Symbol	Rating	Unit
DC Forward Current	IF	5	mA
IC Power Supply Voltage	VDD	+3.8~+5.5	V
IC Input Voltage	VI	-0.4~VDD+0.4	V
Soldering Temperature <sup>*1</sup>	T <sub>SD</sub>	260	°C
Operating Temperature Range		-40°C to +85°C	
Storage Temperature Range		-40°C to +105°C	

**Typical Product Characteristics(VDD=5V;Ta=25°C)**

Characteristics	Symbol	Min.	Typ.	Max.	Unit	Test condition	
Forward Voltage	$V_F$	3.8	5	5.5	V	$I_F=5mA$	
Luminous Intensity	$I_v$	R	40	75	125	mcd	$I_F=5mA$
		G	135	230	390		
		B	15	35	75		
		W	120	300	600		
Dominant Wavelength	$\lambda_d$	R	615	-	630	nm	$I_F=5mA$
		G	520	-	535		
		B	460	-	475		
Color Coordinate	x	-	0.262	-	-	$I_F=5mA$	
	y	-	0.313	-	-		
View Angle	$2\theta_{1/2}$	-	120	-	deg	$I_F=5mA$	

**Range of Bins**
**1) Luminous Intensity-White (VDD=5V; IF = 5mA)**

Bin Code	Min. $I_v$ (mcd)	Max. $I_v$ (mcd)
8	160	210
9	210	270
10	270	350
11	350	460
12	460	600

■ Color Coordinate Comparison-White

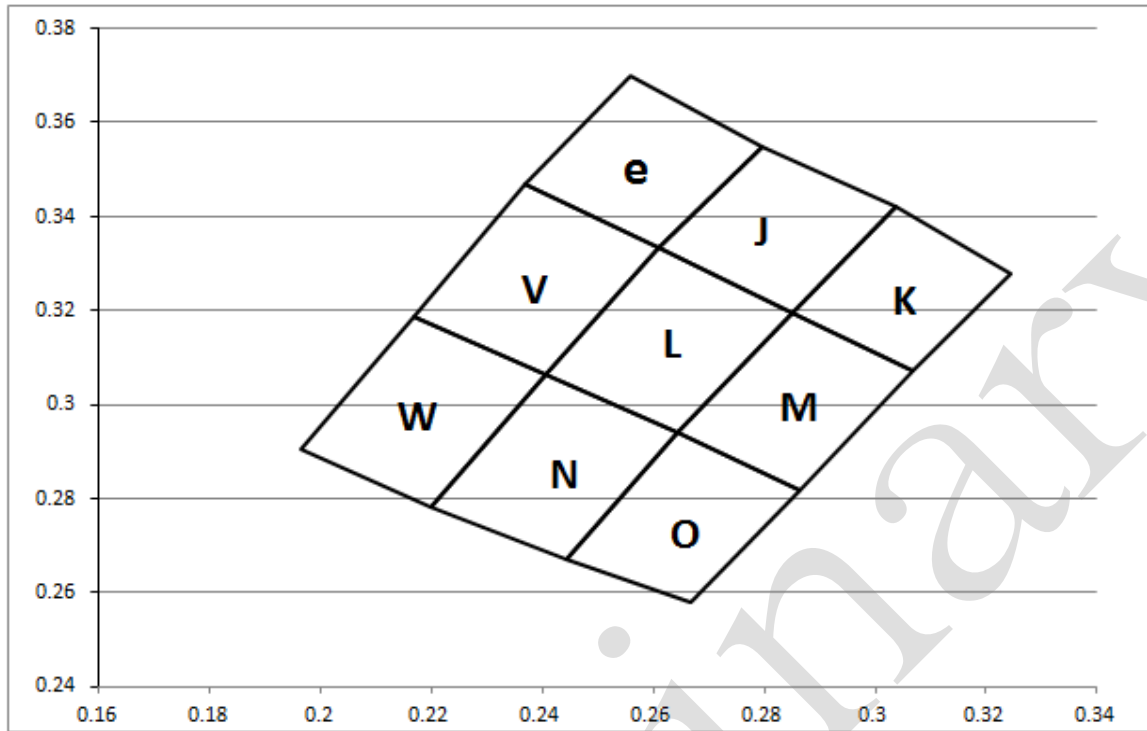

**Color Rank**

Bin	X	Y	X	Y	X	Y	X	Y
e	0.2369	0.3468	0.2609	0.3332	0.2797	0.355	0.2559	0.3698
J	0.2609	0.3332	0.2797	0.355	0.3036	0.342	0.2849	0.3196
K	0.2851	0.3196	0.3036	0.342	0.3243	0.328	0.3068	0.3072
V	0.2169	0.3188	0.2369	0.3468	0.2609	0.3332	0.2406	0.3064
L	0.2406	0.3064	0.2609	0.3332	0.2849	0.3196	0.2643	0.294
M	0.2643	0.294	0.2849	0.3196	0.3068	0.3072	0.2865	0.2819
W	0.1963	0.2907	0.2169	0.3188	0.2406	0.3064	0.22	0.2783
N	0.22	0.2783	0.2406	0.3064	0.2643	0.294	0.2444	0.2672
O	0.2444	0.2672	0.2643	0.294	0.2865	0.2819	0.2667	0.2578

**■ Electrical Characteristics (Ta=25°C)**

Characteristics	Symbol	Condition	Min.	Typ.	Max.	Unit
Static current	I <sub>DD</sub>	V <sub>DD</sub> =4.5V, I <sub>out</sub> = “OFF” ”	-	0.3		mA
Input voltage level	V <sub>IH</sub>	D <sub>IN</sub> , SET	0.7 V <sub>DD</sub>	-	-	V
	V <sub>IL</sub>	D <sub>IN</sub> , SET	-	-	0.3 V <sub>DD</sub>	V

**■ Switching Characteristics (Ta=25°C)**

Characteristics	Symbol	Condition	Min.	Typ.	Max.	Unit
Rate of data signal	FD <sub>IN</sub>		-	0.8	-	MHZ
Transfer time	T <sub>PLH</sub>	D <sub>IN</sub> →D <sub>OUT</sub>	-	-	80	ns
	T <sub>PHL</sub>		-	-	80	ns
Conversion time of I <sub>OUT</sub> R/G/B	Tr	I <sub>OUT</sub> R/G/B =5mA R <sub>L</sub> =400Ω, C <sub>L</sub> =15pF	-	-	50	ns
	Tf		-	-	100	ns

■ Data transfer time (TH+TL=1.2μs±300ns)

1. Timing Wave Form

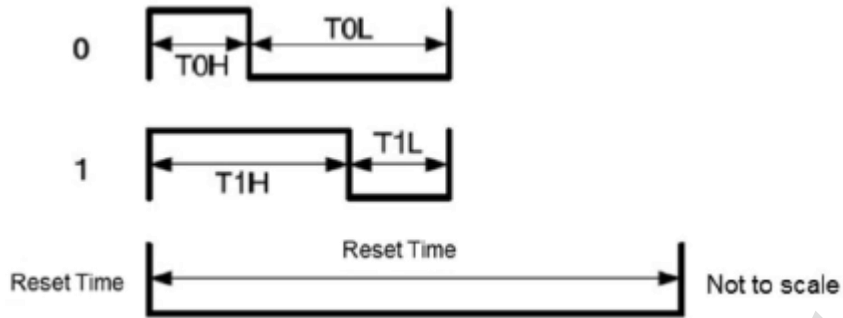

2. High Speed Mode

Item	Description	Typical	Allowance
T <sub>0H</sub>	0 code, high voltage time	300ns	±150ns
T <sub>0L</sub>	0 code, low voltage time	900ns	±150ns
T <sub>1H</sub>	1 code, high voltage time	900ns	±150ns
T <sub>1L</sub>	1 code, low voltage time	300ns	±150ns
RES	reset time	>200us	-

Notes:

- Luminous intensity is measured with a light sensor and filter combination that approximates the CIE eye-response curve.
- $\theta_{1/2}$  is the off-axis angle at which the luminous intensity is half the axial luminous intensity.
- The dominant wavelength,  $\lambda_d$  is derived from CIE chromaticity diagram and represents the single wavelength which defines the color of the device. Peak Emission Wavelength Tolerance is  $\pm 1$ nm.

3. Composition of 24 bit data

R7	R6	R5	R4	R3	R2	R1	R0	G7	G6	G5	G4	G3	G2	G1	G0	B7	B6	B5	B4	B3	B2	B1	B0
----	----	----	----	----	----	----	----	----	----	----	----	----	----	----	----	----	----	----	----	----	----	----	----

bit23.....bit0

4. Data transmission method

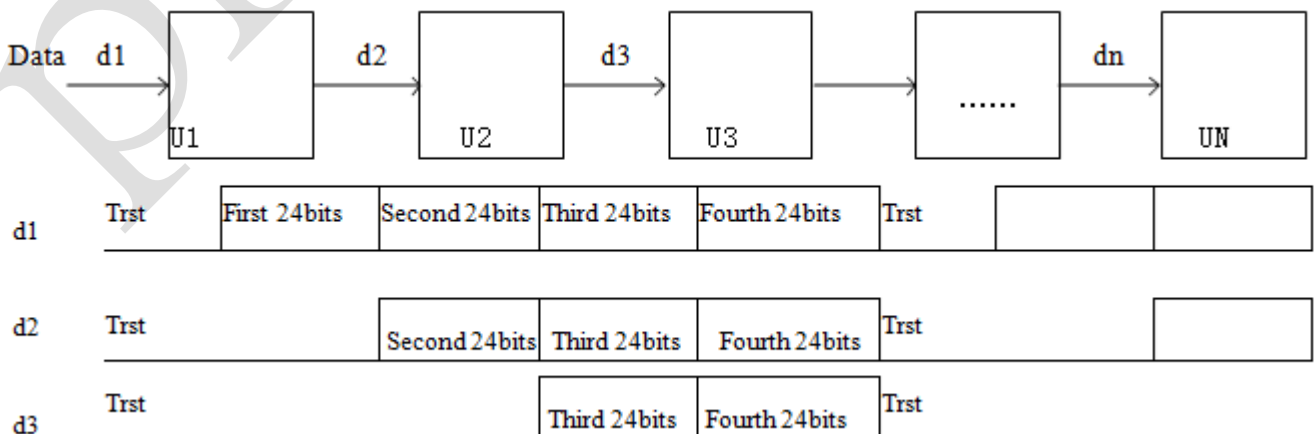

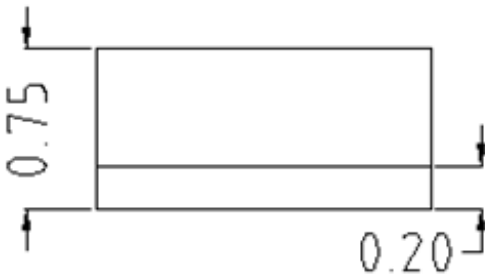
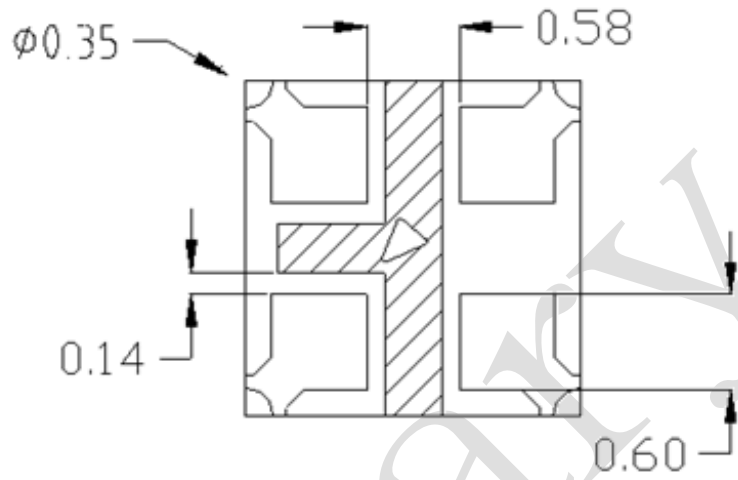
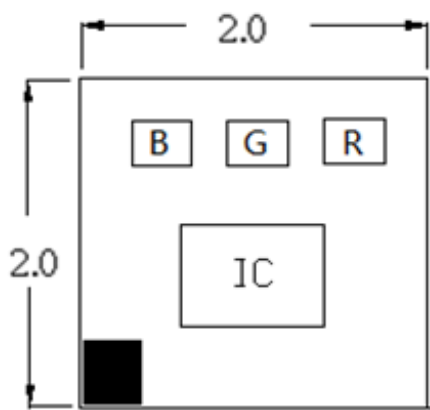
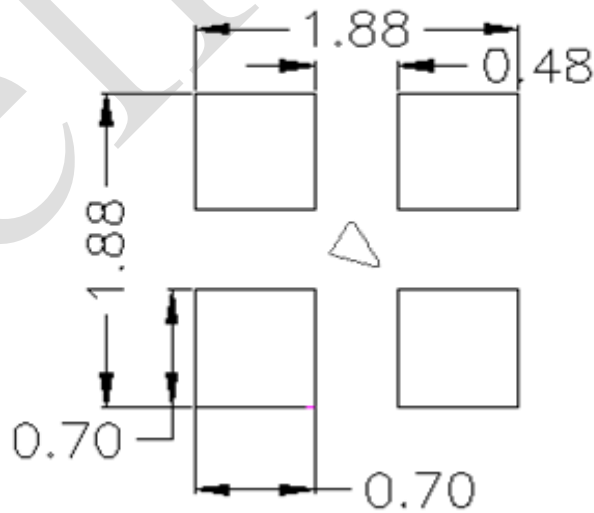
**■ Dimensions**

**RECOMMEND PAD LAYOUT**

- § All dimensions are in millimeters.
- § Tolerance is  $\pm 0.1\text{mm}$  unless other specified
- § Specifications are subject to change without notice

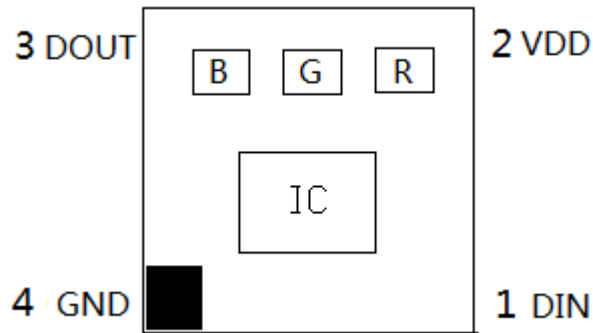
■ PIN Configuration



No.	Symbol	Function description
1	DIN	Control data signal input
2	VDD	Power supply LED
3	DOUT	Control data signal output
4	GND	Ground



■ **Reflow Profile**

**1. IR reflow soldering Profile for Lead Free solder**

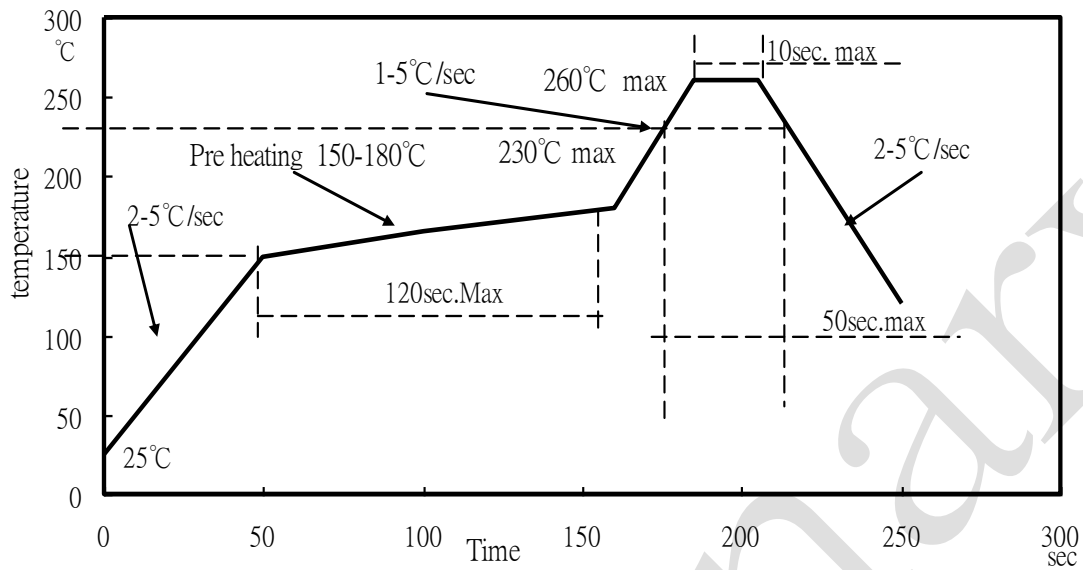

**Notes:**

1. We recommend the reflow temperature at 240°C ( $\pm 5^\circ\text{C}$ ), and the maximum soldering temperature should be limited to 260°C.
2. Don't cause stress to the silicone resin while it is exposed to high temperature.
3. Number of reflow process shall not be more than 1 time.

■ Test Circuit and Precautions for Use

1. Typical application circuit

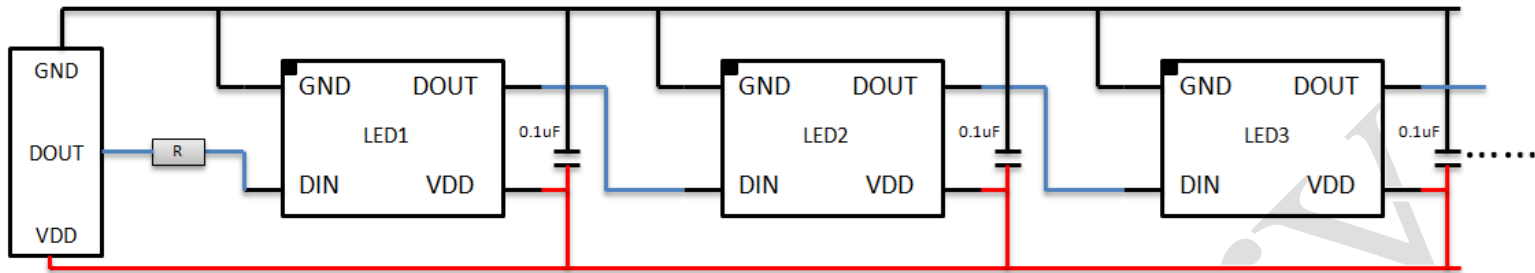

Notes:

When the first LED is connected to the MCU, a resistance R is needed in series between its signal input line and the MCU. The size of R depends on the number of cascade beads. The more cascades, the smaller resistance R is used. It is generally recommended that the value be between 100-1K. Usually the recommended value is around 300 R. In order to make the LEDs work more stably, a parallel capacitor is needed between VDD and GND of each LED.

In order to avoid harmful effects in use, please try to add resistance and capacitance when using. If capacitors and resistors are not added, the number of LEDs on the lamp should be minimized, but this way still does not exclude the risk of problems.

2. Precautions for Use

2.1. Over-current-proof

Customer must apply resistors for protection; otherwise slight voltage shift will cause big current change (Burn-out will happen).

2.2. Storage

1). To store the products is recommended with following conditions:

Humidity: 60% R.H. Max.

Temperature: 5°C~30°C (41°F~86°F)

2). Shelf life in sealed bag: 12 months at <5°C~30°C and <60% R.H. after the package is Opened, the products should be used within 72 hours or they should be stored at ≤20%R.H. with zip-lock sealed bag.

2.3. Baking

The products are not used up within 72 hours, and please bake them before using:

1). 60±3°C X 6hrs and <5% RH, for reel

2). 125±3°C X 2hrs, for single LED

It is normal to see slight color fading of carrier (light yellow) after baking in process.

■ Packing

● Feeding Direction

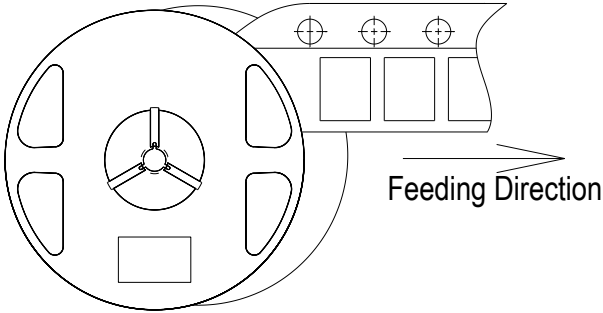

● Dimensions of Reel (Unit: mm)

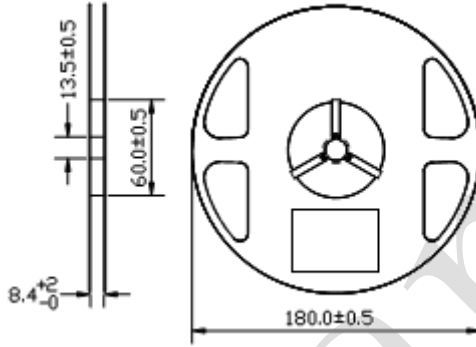

● Dimensions of Tape (Unit: mm)

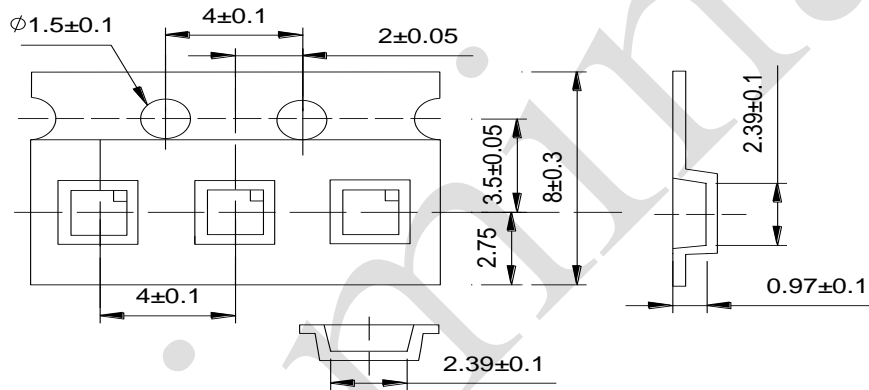

● Arrangement of Tape

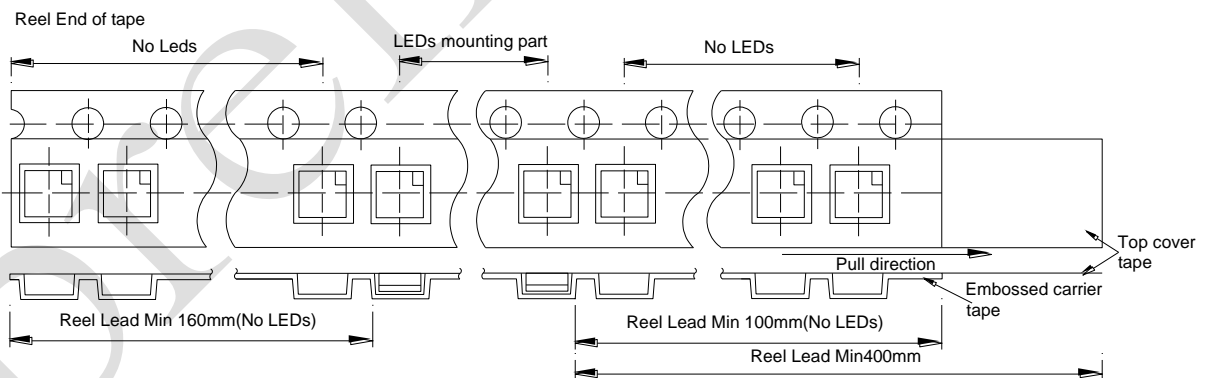

Notes:

1. Empty component pockets are sealed with top cover tape;
2. The max loss number of SMD is 2pcs;
3. The cathode is oriented towards the tape sprocket hole in accordance with ANSI/EIA RS-481 specifications;
4. 4000pcs per reel

■ Packing

● Packaging Specifications

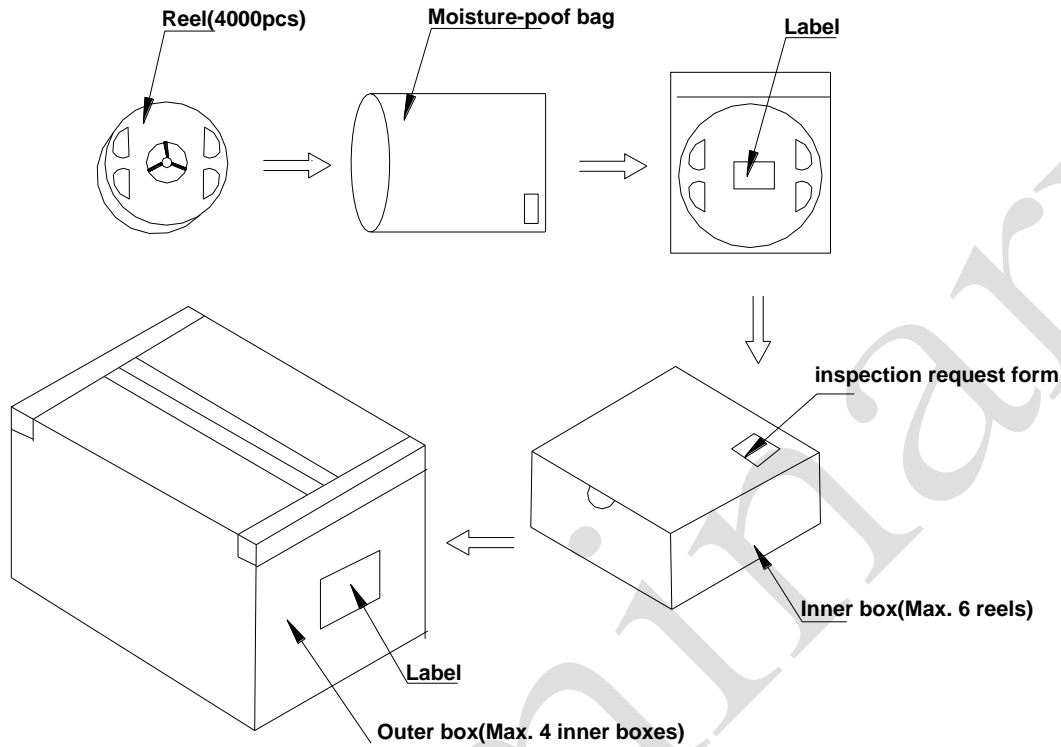

**Notes:**

Reeled product (max.4,000) is packed in a sealed moisture-proof bag. Six bags are packed in an inner box (size: about 260 X 230 X 100 mm) and four inner boxes are in an outer box (size: about 480 X 275 X 215 mm). On the label of moisture-pooof bag, there should be the information of Part No., Lot No. and quantity number; also the total quantity number should be on inspection request form on outer box.

■ **Precautions**

---

**1. Abnormal situation caused by improper setting of collet**

To choose the right collet is the key issue in improving the product's quality. LED is different from other electronic components, which is not only about electrical output but also for optical output. This characteristic made LED more fragile in the process of SMT. If the collet's lowering down height is not well set, it will bring damage to the gold wire at the time of collet's picking up and loading which will cause the LED fail to light up, light up now and then or other quality problems

**2. How to choose the collet**

During SMT, please choose the collet that has larger outer diameter than the lighting area of lens, in case that improper position of collet will damage the gold wire inside the LED. Different collets fit for different products, please refer to the following pictures cross out

**Outer diameter of collet should be larger than the lighting area**

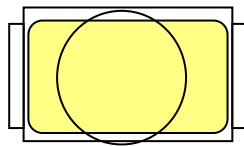

Picture 1(√)

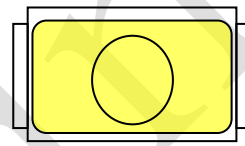

Picture 2(X)

**3. Other points for attention**

A. No pressure should be exerted to the epoxy shell of the SMD under high temperature.

B. Do not scratch or wipe the lens since the lens and gold wire inside are rather fragile and cross out easy to break.

C. LED should be used as soon as possible when being taken out of the original package, and should be stored in anti-moisture and anti-ESD package.

**4. This usage and handling instruction is only for your reference.**

■ Test Items and Results of Reliability

Test Item	Test Conditions	Duration/ Cycle	Ac/Re	Number of Damage	Reference
Normal Temperature Life	Ta= 23°C (±5°C) IF=5mA	1008 hrs	0/1	0/22	JESD22 A-108
High Temperature Life	Ta= 85°C (±5°C) IF=5mA	1008 hrs	0/1	0/22	JESD22 A-108
High Humidity Heat Life	Ta= 85°C (±5°C) RH=85% IF=5mA	1008 hrs	0/1	0/22	JESD22 A-108
Thermal shock	-45°C/30min~105°C /30min (±5°C)	1008 hrs	0/1	0/22	JESD22 A-104
Electrostatic Discharge (ESD) Test	According to the SPEC	3 cycles	0/1	0/22	AEC Q101-001
Low Temperature Storage	Ta=-40°C	1008 hrs	0/1	0/22	JESD22-A103D
High Temperature Storage	Ta=105°C	1008 hrs	0/1	0/22	JESD22-A103D

*Criteria for Judging				
Item	Symbol	Condition	Criteria for Judgment of Pass	
			Min	Max
Luminous Intensity	Iv	IF=5mA	LSL <sup>*2</sup> ×0.7	-

[Note] LSL<sup>\*2</sup>: Lower Specification Level