

SPECIFICATION FOR APPROVAL

Customer	:	
Customer Part No.	:	
Brightek Part No.	:	5F1519AW5FFMZYN
Time	:	2021/07/14

Customer Confirmation	Approval	Checkedy	Prepared By
	F.WU	WH.LI	X.ZHOU

5F1519AW5FFMZYNG

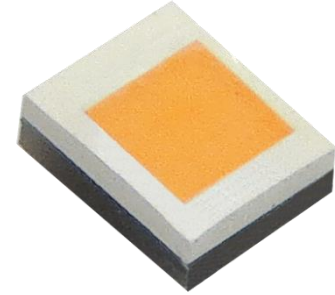

- ◆ Outline : 1.5*1.9*0.8mm
- ◆ High Power Output And High efficiency
- ◆ Good thermal dissipation & Optical uniformity

Table of Contents:

Features-----	2
Product Code-----	3
Typical Product Characteristics-----	4
Maximum Rating-----	5
Luminous Intensity Binning-----	6
Forward Voltage Binning-----	6
Color Coordinate Binning-----	7
Relative Spectral Power Distribution-----	8
Typical Diagram Characteristics of Radiation-----	8
Electronic-Optical Characteristics-----	9
Thermal Design for De-rating-----	10
Dimensions-----	11
Suggest Stencil Pattern-----	11
Packaging-----	12
Reflow profile-----	14
Precautions-----	15
Test items and results of reliability-----	17

Features

- RoHS and REACH-compliant
- MSL2 qualified according to JEDEC J-STD 020
- ESD 8KV (HBM : ANSI/JEDEC JS-001 Class 3B)
- AEC-Q102 Qualified

Applications

- Automotive Exterior Lighting

■ Product Code

5 – F – 1519 – A – W5FF – M – Z – Y – N – G

① ② ③ ④ ⑤ ⑥ ⑦ ⑧ ⑨ ⑩

①	②	③	④	⑤
Process type	Category	Specification	Lens Angle code	Dice wavelength & Luminous rank
5:For Automotive	F: Flip Chip LED	1519: 1.5*1.9mm	A : 120°	W5xx: Amber

⑥	⑦	⑧	⑨	⑩
Support code	Zener & High CRI	Cap color code	Module & Lens code	Current code
M: AlN (Au)	Z: Zener	Y: 1700K	N: Paintings	G: 500mA for test

■ Typical Product Characteristics(Ta=25°C)

Item	Symbol	Value			Unite	Test Condition
		Min.	Typ.	Max.		
Forward Voltage¹	V _F	2.8		3.6	V	I _F =500mA
Reverse Current	I _R			10	μA	V _R =5V
Luminous Intensity²	Φ	80		120	lm	I _F =500mA
Viewing Angle³	2θ _{1/2}		120		deg	I _F =500mA
Correlated Color Temperature	CCT		1700		K	I _F =500mA

Notes:

1. The above forward voltage measurement allowance tolerance is ±0.05V
2. The above luminous flux measurement allowance tolerance ±7%
3. The above Viewing angle (2θ_{1/2}) measurement allowance tolerance ±10°
4. IS standard test.

■ Maximum Rating (Ta =25°C)

Characteristics	Symbol	Min.	Typ.	Max.	Unit
DC Forward Current¹	I _F			1500	mA
Pulse Forward Current²	I _{PF}			3000	mA
Reverse Voltage	V _R			5	V
Junction Temperature³	T _J			150	°C
Thermal Resistance Junction/ Solder Point	R _{THJ-S}		6		°C/W
Operating Temperature Range	T _{OPR}	-40	–	125	°C
Storage Temperature Range	T _{STG}	-40	–	125	°C
Soldering Temperature	T _{SD}			260	°C

Notes:

1. For other ambient, limited setting of current will depend on de-rating curves.
2. Duty 1/10, pulse width 10ms
3. When drive on maximum current , T_J must be kept below 150°C

■ Luminous Intensity Binning (IF=500mA)

Bin Code	Min. Φ_v (Lm)	Max. Φ_v (Lm)
B31	80	90
B32	90	100
B33	100	110
B34	110	120

■ Forward Voltage Binning (IF=500mA)

Bin Code	Min. V_F (V)	Max. V_F (V)
V2830	2.8	3.0
V3032	3.0	3.2
V3234	3.2	3.4
V3436	3.4	3.6

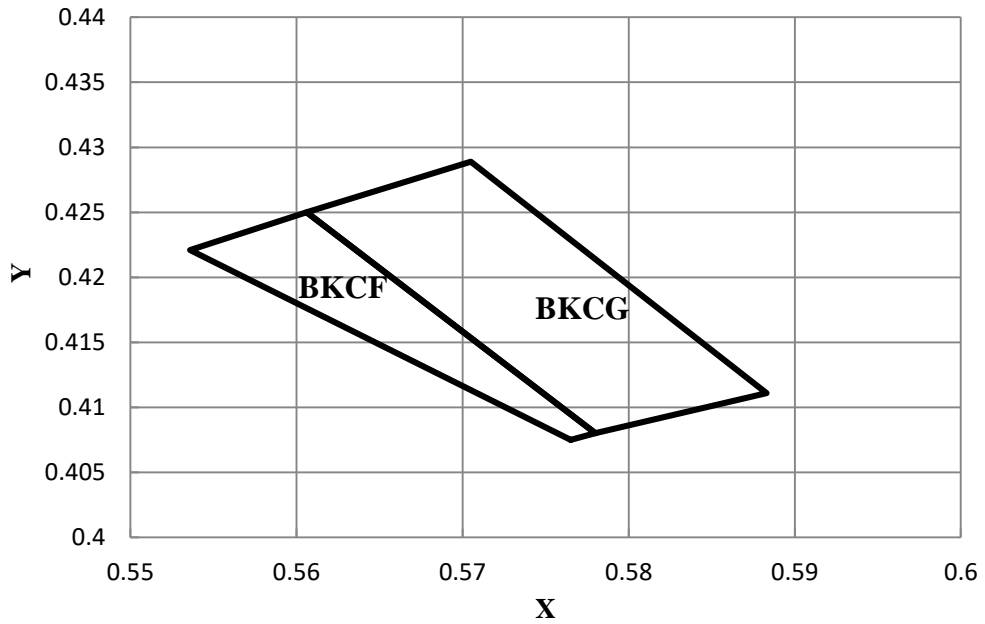
■ Color Coordinate Binning (IF=500mA)

BIN	CIE X	CIE Y	BIN	CIE X	CIE Y
BKCF	0.5765	0.4075	BKCG	0.578	0.408
	0.5536	0.4221		0.5606	0.425
	0.5606	0.425		0.5705	0.4289
	0.578	0.408		0.5883	0.4111

Notes:

The above color coordinates (CIE x, CIE y) measurement allowance tolerance is ± 0.007

■ Relative Spectral Power Distribution

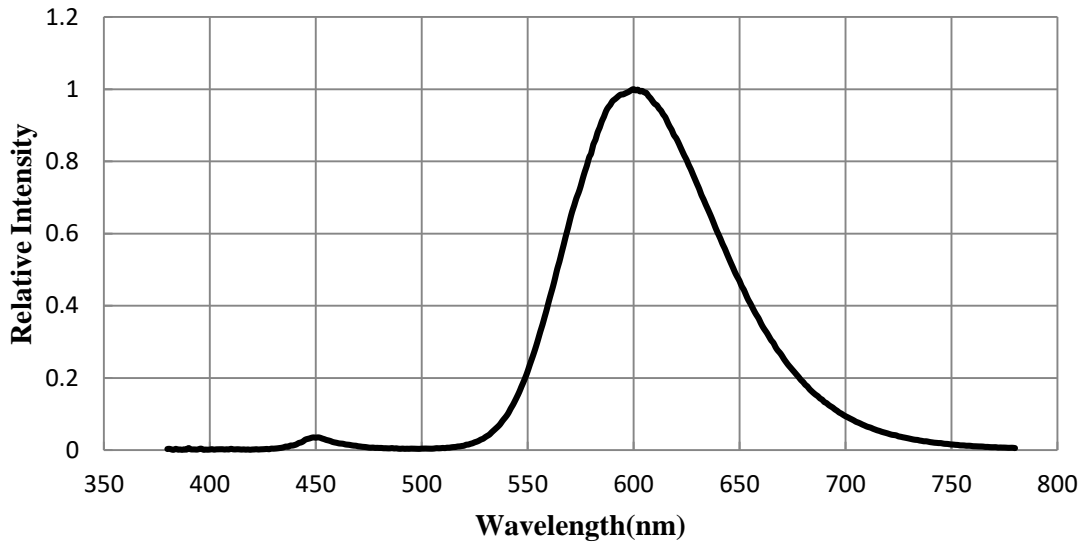

■ Typical Diagram Characteristics of Radiation

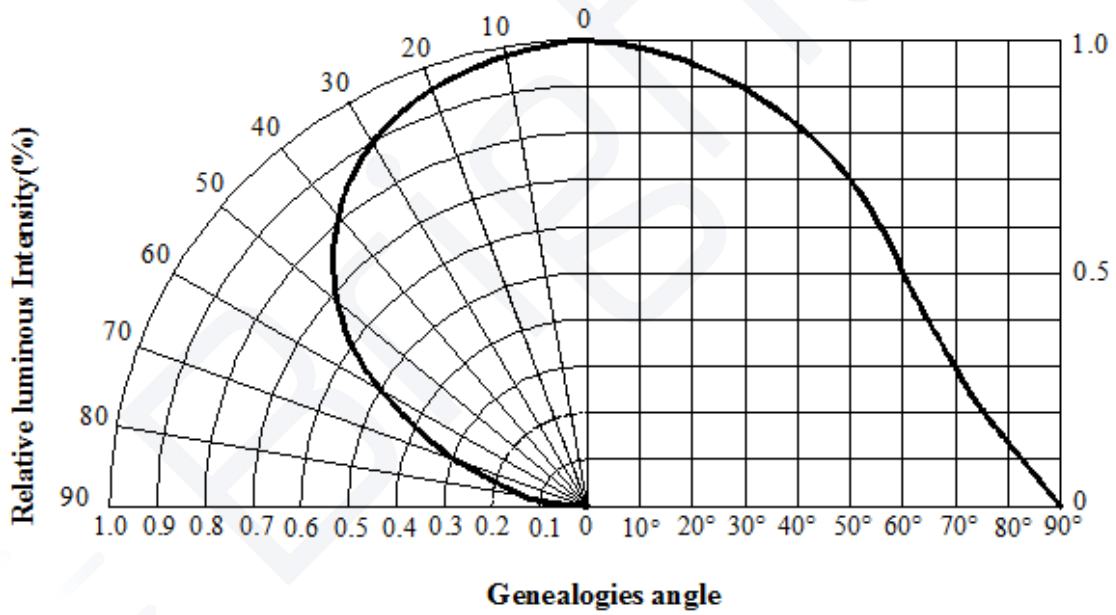

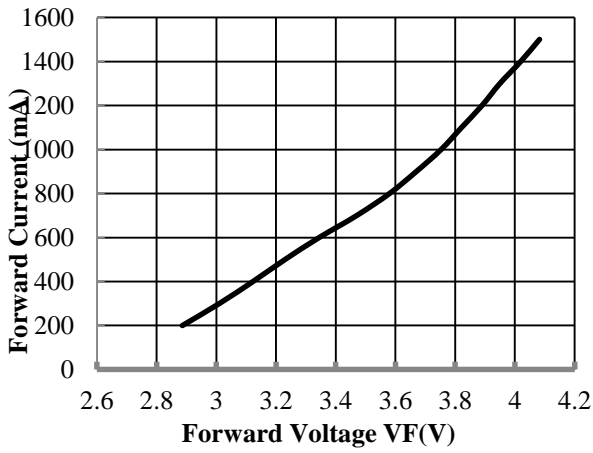
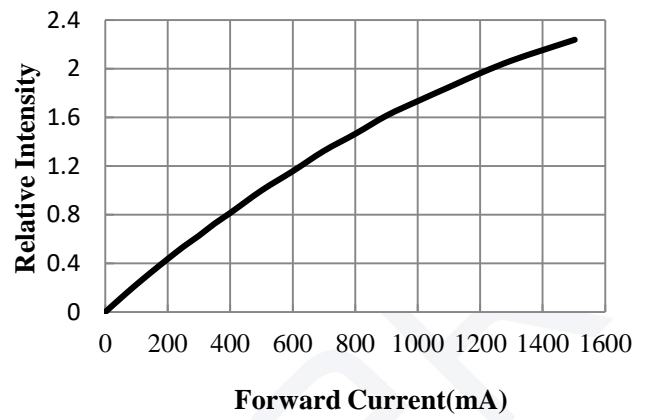
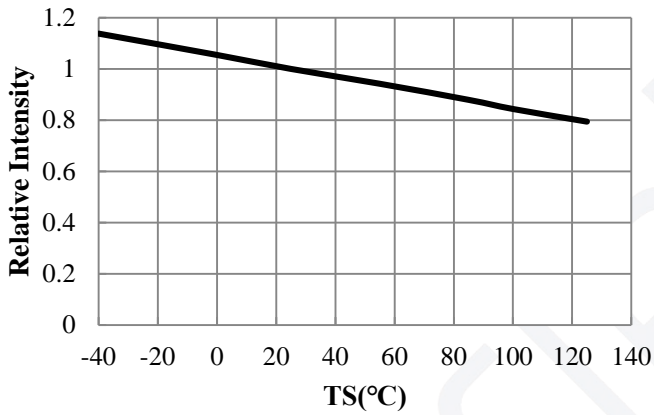
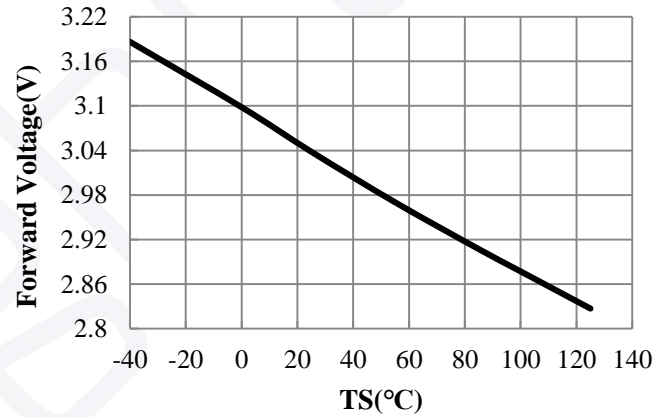
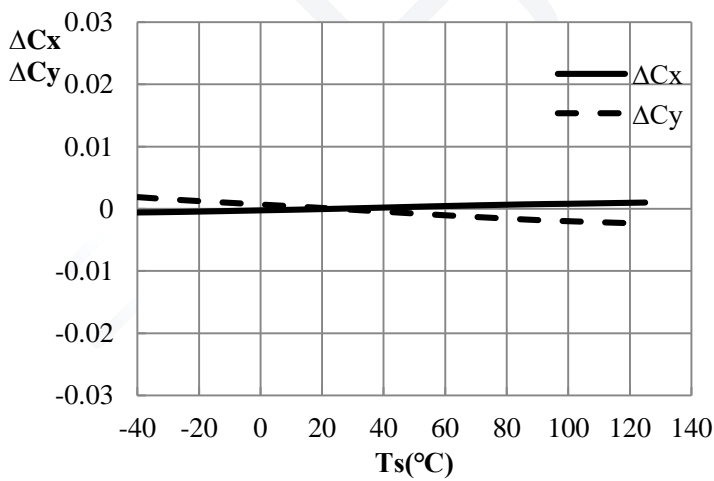
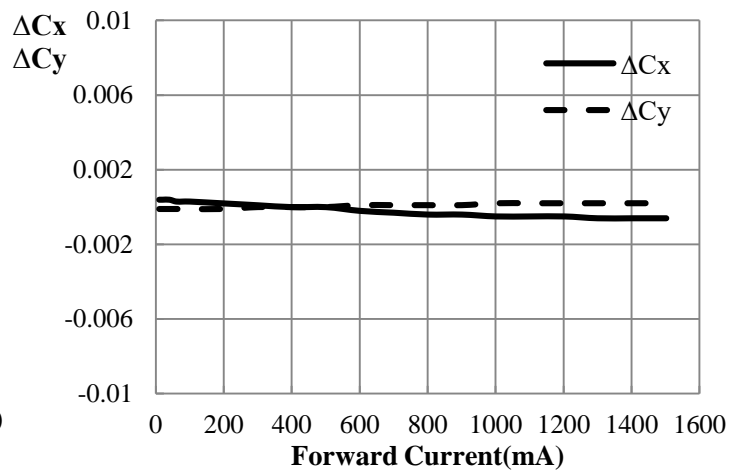
Electronic-Optical Characteristics
Forward Current vs. Forward Voltage

Relative Intensity vs. Forward Current

Relative Luminous Flux vs. Solider Temperature

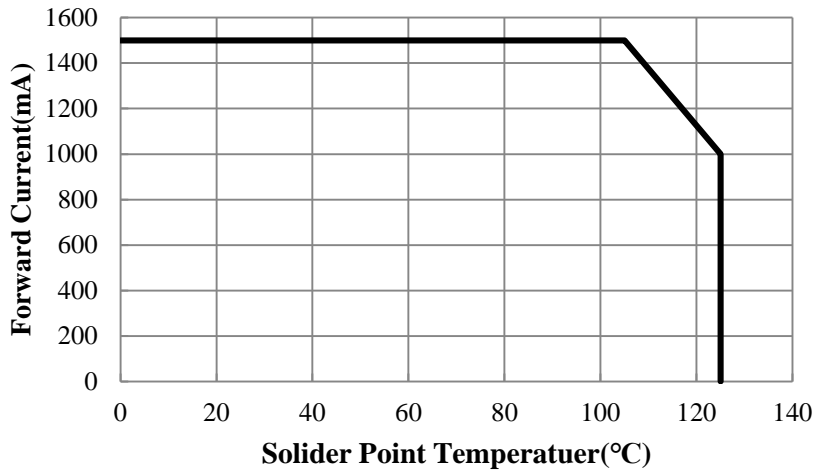
Forward Voltage vs. Solider Temperature

Chromaticity Coordinate Shift vs. Solider Temperature

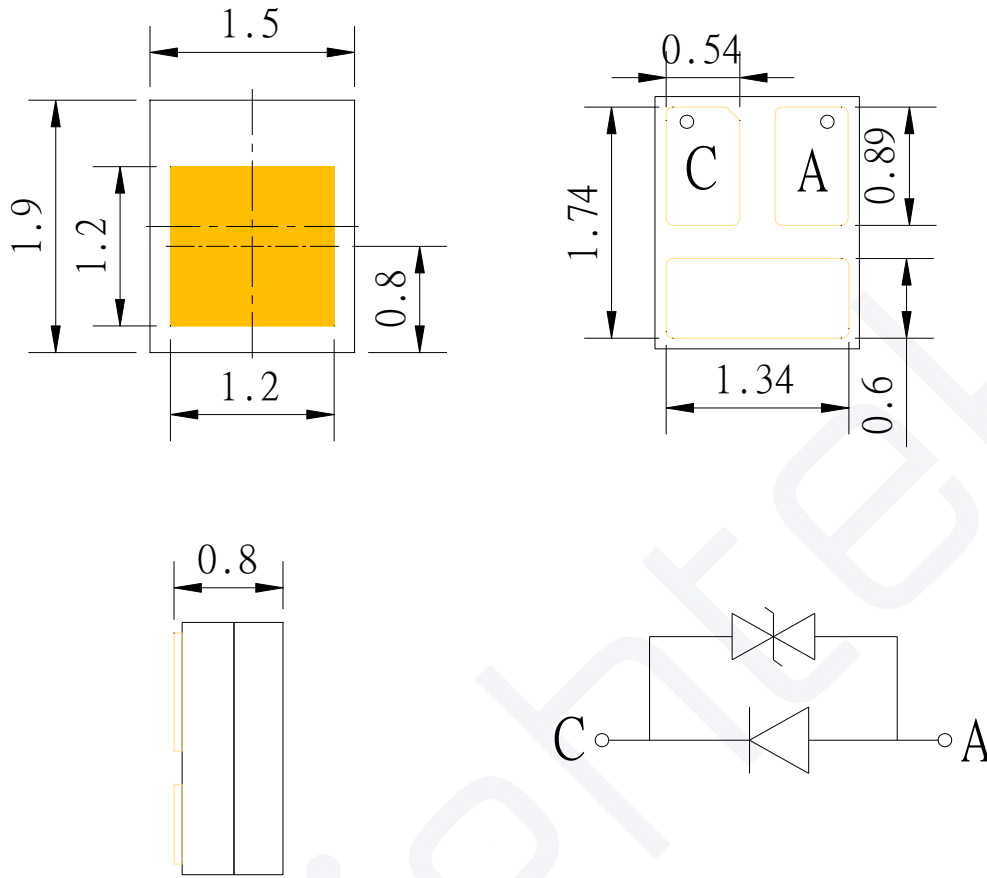
Chromaticity Coordinate Shift vs. Forward Current

■ Thermal Design for De-rating

The maximum forward current is determined by the thermal resistance between the LED junction and solder point. It is crucial for the end product to be designed in a manner that minimizes the thermal resistance from the solder point to ambient in order to optimize lamp life and optical characteristics.



■ Dimensions



§ All dimensions are in millimeters.
 § Tolerance is $\pm 0.13\text{mm}$ unless other specified.

■ Suggest Stencil Pattern (Recommendations for reference)

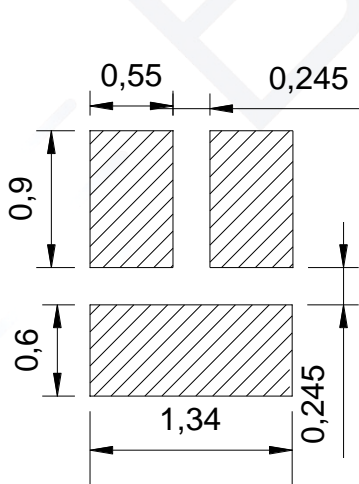

RECOMMENDED PCB SOLDER PAD

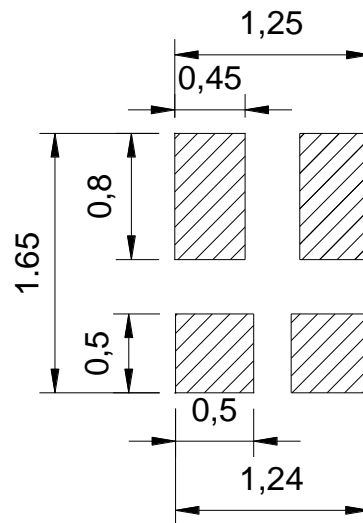

RECOMMENDED STENCIL PATTERN
 (HATCHED AREA IS OPENING)

§ Suggest stencil $t = 0.12\text{ mm}$

■ Packaging

● Feeding Direction (Unit: mm)

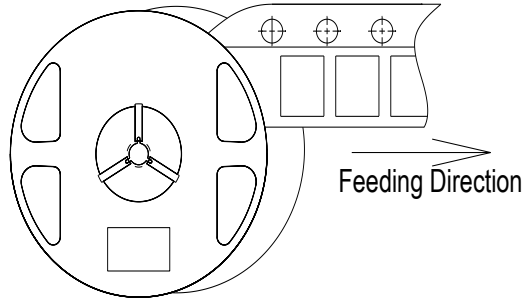

● Dimensions of Reel (Unit: mm)

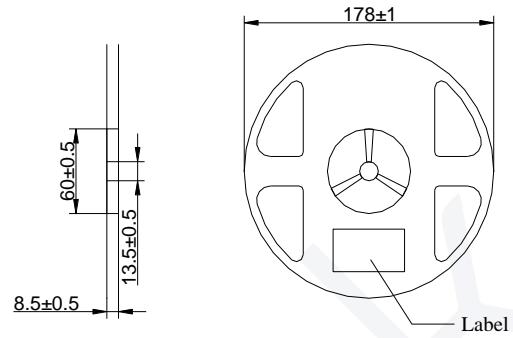

● Dimensions of Tape (Unit: mm)

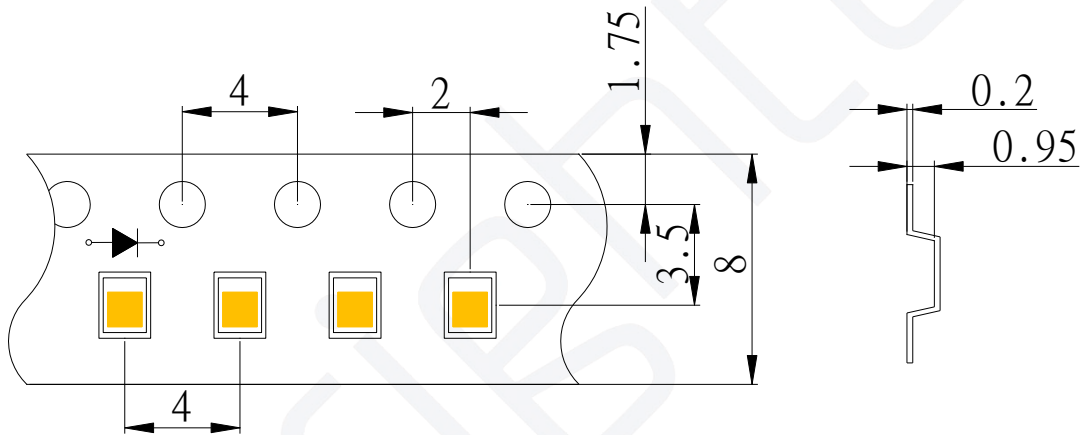

● Arrangement of Tape

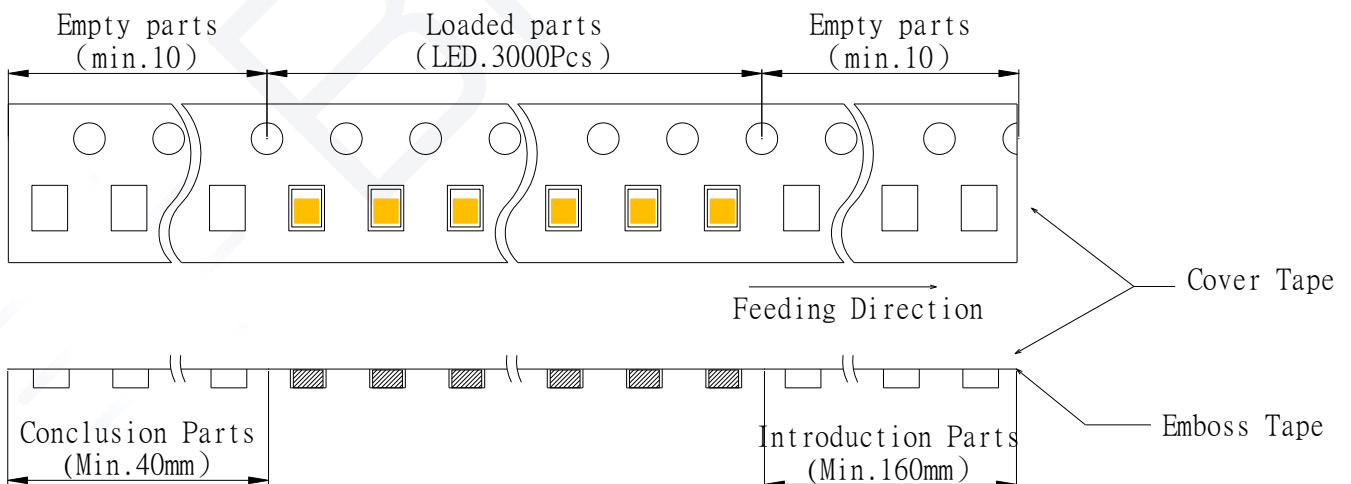

Notes:

1. Empty component pockets are sealed with top cover tape
2. The max loss number of SMD is 2pcs;
3. The cathode is oriented towards the tape sprocket hole in accordance with ANSI/EIA RS-481 specifications;
4. 3,000pcs per reel;
5. The remainder packing in multiples of 500pcs.

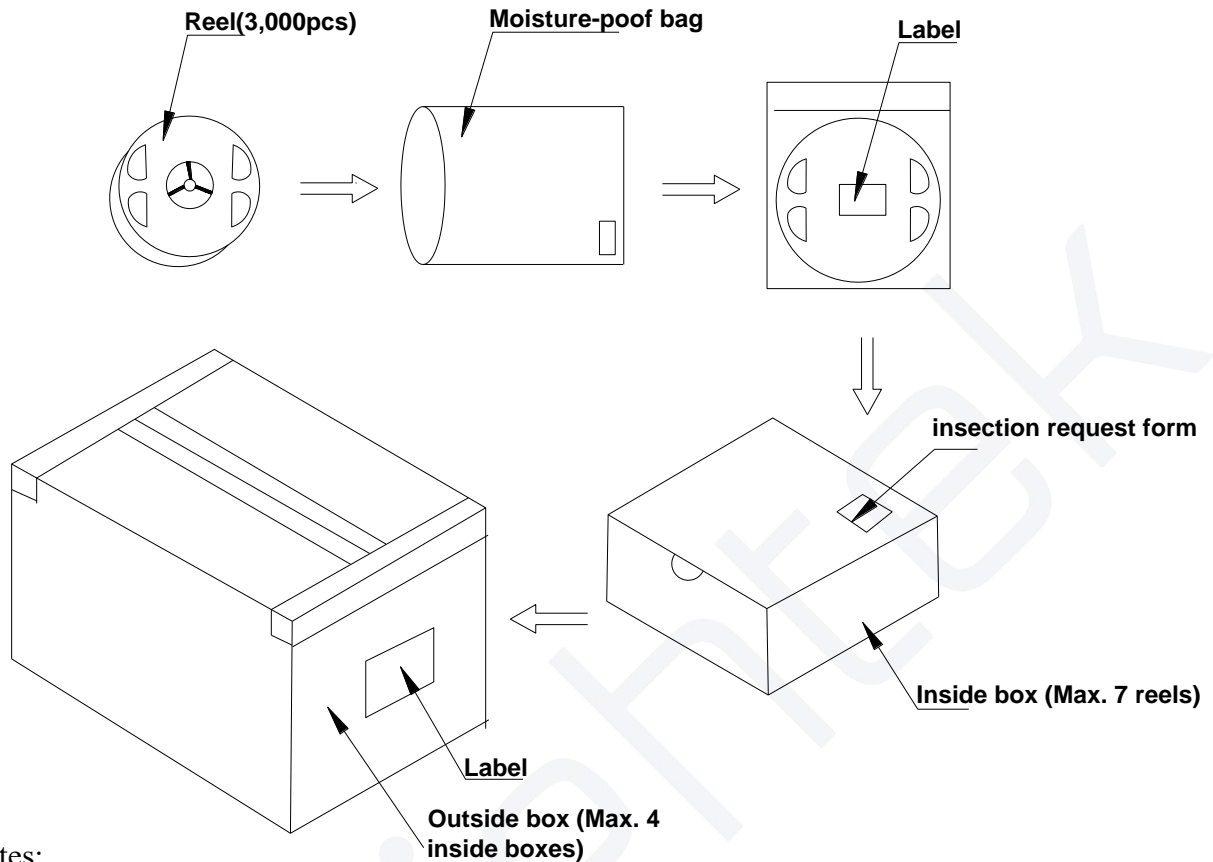
■ Packaging

Notes:

Reeled product (max.3,000) is packed in a sealed moisture-proof bag. Seven bags are packed in an inner box (size: about 260 X 230 X 100 mm) and four inner boxes are in an outer box (size: about 480 X 275 X 215 mm). On the label of moisture-proof bag, there should be the information of Part No., Lot No. and quantity number; also the total quantity number should be on inspection request form on outer box.

■ Reflow Profile

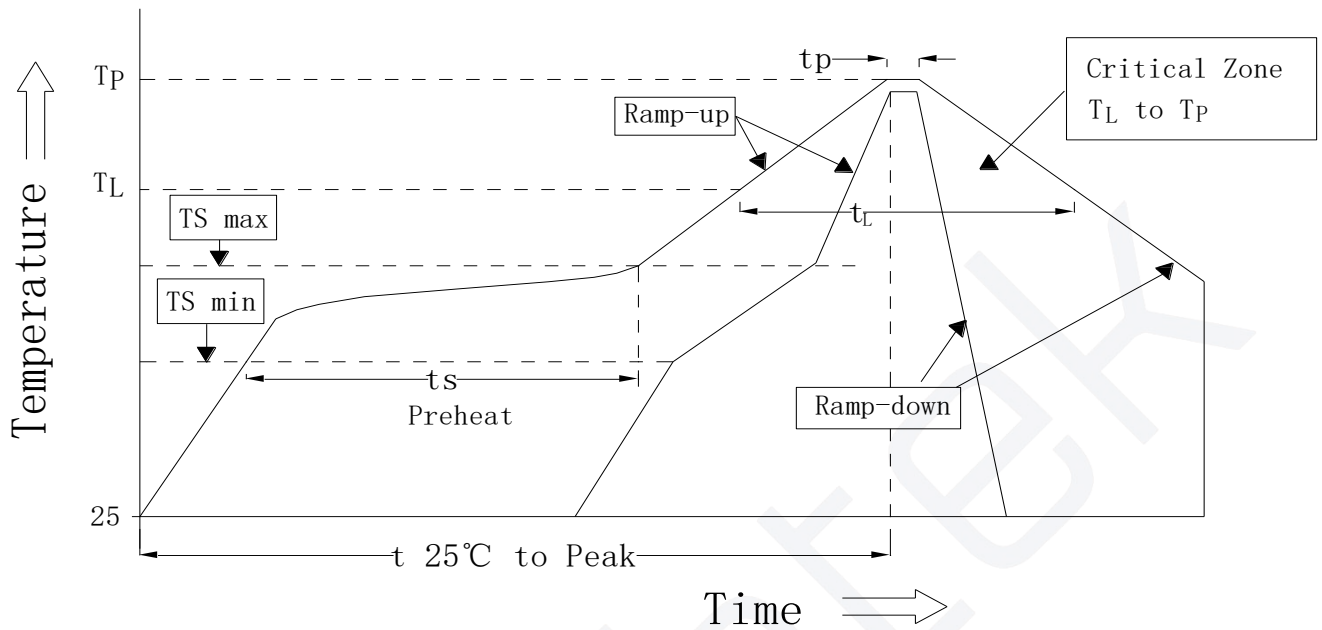
SMT Reflow Soldering Profile



Profile Feature	Symbol	Pb-Free (SnAgCu) Assembly			Unit
		Min.	Recommendation	Max.	
Ramp-up rate to preheat (25°C to 150°C)			2	3	K/s
Time t_s ($T_{S\ min}$ to $T_{S\ max}$)	t_s	60	100	120	s
Ramp-up rate to peak ($T_{S\ max}$ to T_P)			2	3	K/s
Liquidus temperature	T_L		217		°C
Time above liquidus temperature	t_L		80	100	s
Peak temperature	T_P		245	260	°C
Time within 5 °C of the specified peak temperature $T_P - 5\text{K}$	t_p	10	20	30	s
Ramp-down Rate (T_P to 100 °C)			3	4	K/s
Time 25 °C to T_P				480	s

Notes:

1. Do not stress the silicone resin while it is exposed to high temperature.
2. The reflow process should not exceed 2 times.

■ Precautions



1. Recommendation for using LEDs

- 1.1 The lens of LEDs should not be exposed to dust or debris. Excessive dust and debris may cause a drastic decrease in the luminosity.
- 1.2 Avoid mechanical stress on LED lens.
- 1.3 Do not touch the LED lens surface. It would affect the optical performance of the LED due to the LED lens' damage.
- 1.4 Pick & place tools are recommended for the remove of LEDs from the factory tape & reel packaging

2. Lens handling

Please follow the guideline to pick LEDs.

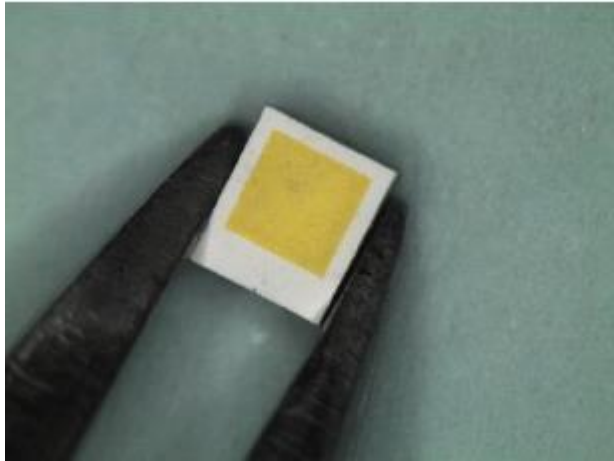
- 2.1 Use tweezers to pick LEDs.
- 2.2 Do not touch the lens by using tweezers.
- 2.3 Do not touch lens with fingers.
- 2.4 Do not apply more than 4N (400gw) directly onto the lens.

Correct (✓)	Wrong (X)
	

3. Lens cleaning

In the case which a small amount of dirt and dust particles remain on the lens surface, a suitable cleaning solution can be applied.

- 3.1 Try a gentle wiping with dust-free cloth.
- 3.2 If needed, use dust-free cloth and isopropyl alcohol to gently clean the dirt from the lens surface.
- 3.3 Do not use other solvents as they may directly react with the LED assembly.
- 3.4 Do not use ultrasonic cleaning which will damage the LEDs.

4. Carrier tape handling

The following items are recommended when handling the carrier tape of LEDs.

- 4.1 Do not twist the carrier tape.
- 4.2 The inward bending diameter should not be smaller than 6cm for each carrier tape.

4.3 Do not bend the tape outward.

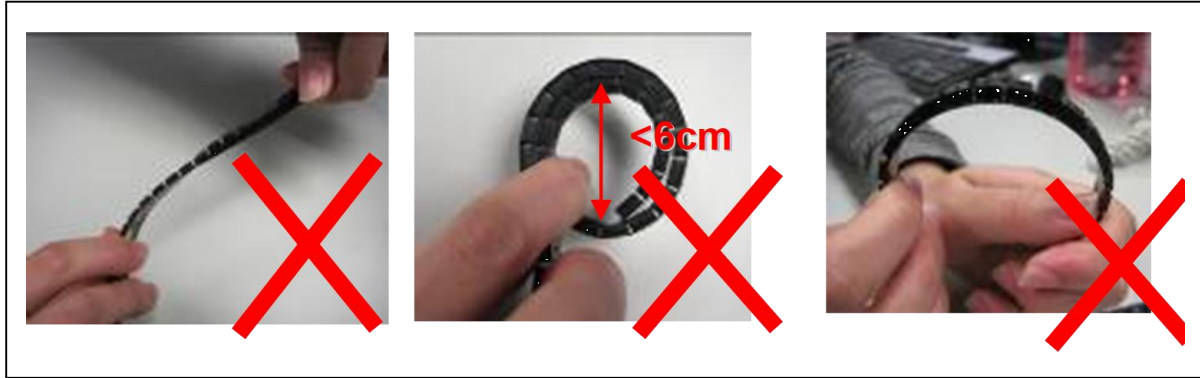

5. Storage

5.1 The moisture-proof bag is sealed :

The LEDs should be stored at 30°C or less and 90%RH or less. And the LEDs are limited to use within one year, while the LEDs is packed in moisture-proof package with the desiccants inside.

5.2 The moisture-proof bag is opened :

The LEDs should be stored at 30°C or less and 60%RH or less. Moreover, the LEDs are limited to solder process within 168hrs. If the humidity indicator card shows the pink color in 10% even higher or exceed the storage limiting time since opened, that we recommended to baking LEDs at 60°C at least 24hrs. To seal the remainder LEDs return to the moisture-proof bag, it's recommended to be with workable desiccants.

■ Test Items and Results of Reliability

Test Item	Test Conditions	Duration/ Cycle	Number of Damage	Reference
Thermal Shock	-40°C 30min ↑↓5min 125°C 30min	1000 cycles	0/26	JESD22 A-106
High Temperature Storage	T _a =105°C	1000 hrs	0/26	JESD22 A-103B
Low Temperature Storage	T _a =-40°C	1000 hrs	0/26	JESD22 A-119
Life Test	T _a =25°C I _f =1500mA	1000 hrs	0/26	JESD22 A-108
High Humidity Heat Operation	85°C RH=85% I _f =500mA	1000 hrs	0/26	JESD22 A-101
High Temperature Operation	T _a =105°C I _f =500mA	1000 hrs	0/26	JESD22 A-108C
ESD(HBM)	8KV at 1.5kΩ;100pF	3 Times	0/30	ANSI/JEDEC JS-001

Failure Criteria				
Item	Symbol	Condition	Criteria for Judgment	
			Min	Max
Forward Voltage	V _F	I _f =500mA	-	USL ¹ ×1.1
Reverse Current	I _R	V _R =5V	-	10μA
Radiant Power	P _O	I _f =500mA	LSL ² ×0.7	-

Notes

1. USL: Upper specification level
2. LSL: Lower specification level