

SA0603W50BBZ2

0603 Series (L* W*H): 1.6*1.0*0.80mm



Applications

- Indicator and backlighting for all consumer electronics
- Special application

Features

- Forward current: $\leq 20\text{mA}$;
- Typical view angle 50% Iv:55°
- Good thermal dissipation & optical uniformity
- Lens color: Black
- Emitting color: White
- RoHS2.0 and REACH-compliant
- ESD level 6kV(HBM)

SA0603W50BBZ2

Dimensional Drawing

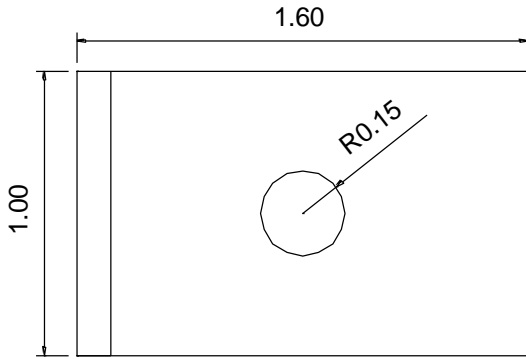

Top View

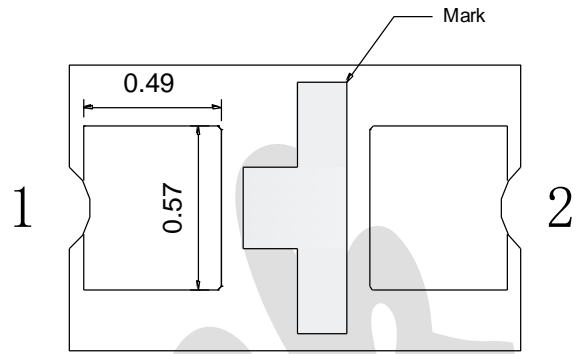

Bottom View

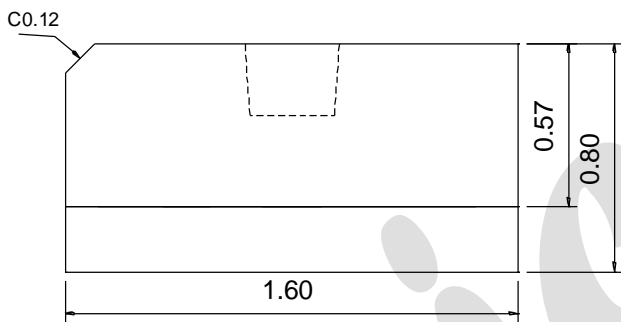

Side View

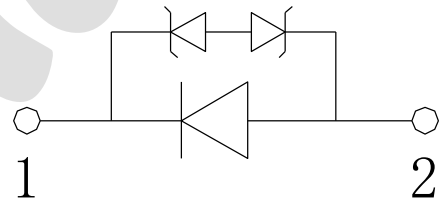

Recommend Padlayout

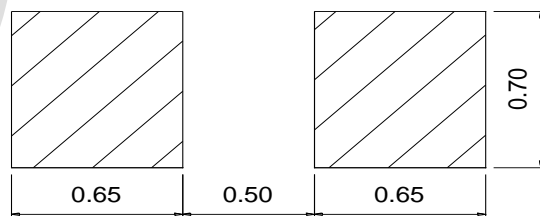

1. Dimensions are in millimeters.
2. General tolerance is ± 0.1 mm.

SA0603W50BBZ2

Naming Rule

SA-0603-W50-B-B-Z2

SA	0603	W50	B	B	Z2
Type	Package Size	Color	Lens color	Output current	Serial number
SA: PCB planar LED	0603: 1.6*1.0mm	W**:White e	B:Black	B:5mA	Z: zener 2: Serial number

Maximum Ratings

T_A : 25 °C

Parameter	Symbol		Typical	Unit
Forward current	I _F	max.	20	mA
Pulse forward current	I _{PF}	max.	80	mA
Power Dissipation	P _D	max.	60	mW
Reverse voltage	V _R	max.	5	V
Operating temperature	T _{op}	min.	-40	°C
		max.	85	
Storage temperature	T _{stg}	min.	-40	°C
		max.	85	
Soldering temperature	T _{SD}	max.	260	°C

1. There is no maximum or typical voltage parameter.
2. For other ambient, limited setting of current will be depended on de-rating curves.
3. Duty 1/10, pulse width 0.1ms.

The maximum of soldering time is 10 seconds in T_{SD}.

SA0603W50BBZ2

Typical Product Characteristics (Ta=25°C)

Characteristics	Symbol	Min.	Typ.	Max.	Unit	Test condition
Forward Voltage	VF	2.4	-	3.0	V	IF=5mA
Reverse Current	IR	-	-	10	μA	VR= 5V
Luminous Intensity	Iv	40	64	80	mcd	IF=5mA
View Angle	2θ1/2	-	55	-	deg	IF=5mA
Color Coordinate	X	-	0.26	-	-	IF=5mA
	Y	-	0.24	-	-	

1. Tolerance of Measure:

Forward Voltage: ±0.1V, Luminous Intensity: ±10%*mcd*, Color Coordinate(x, y): ±0.006

Range of Bins

1.Forward Voltage Bins (IF=5mA)

Bin Code	Min.	Max.
A	2.4	2.5
B	2.5	2.6
C	2.6	2.7
D	2.7	2.8
E	2.8	2.9
F	2.9	3.0

2.Luminous Lumen Bins (IF=5mA)

Bin Code	Min.	Max.
8	40	50
9	50	63
10	63	80

Color Coordinate Comparison

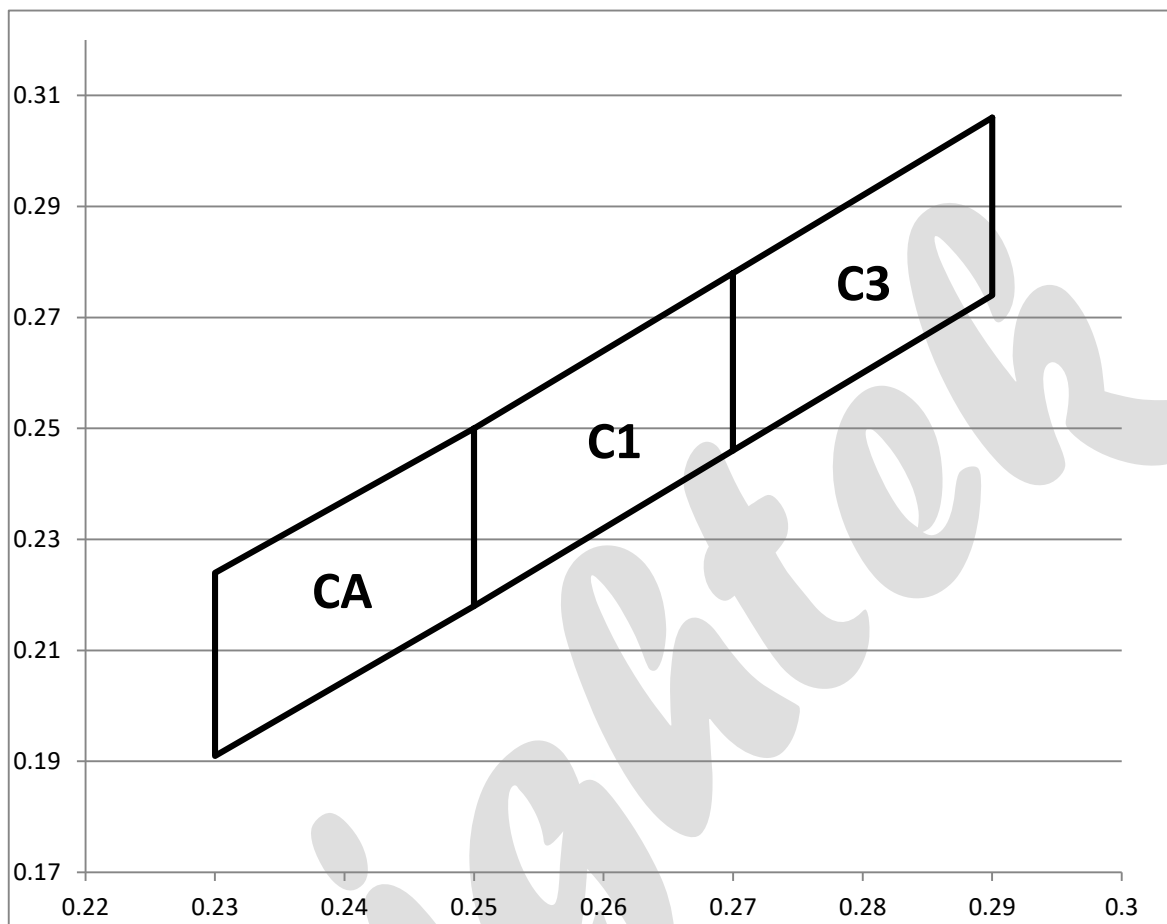

Color Rank

Bin	X	Y	X	Y	X	Y	X	Y
CA	0.25	0.25	0.23	0.224	0.23	0.191	0.25	0.218
C1	0.27	0.278	0.25	0.25	0.25	0.218	0.27	0.246
C3	0.29	0.306	0.27	0.278	0.27	0.246	0.29	0.274

Typical Electrical Optical Characteristics Curves

Radiation Characteristics

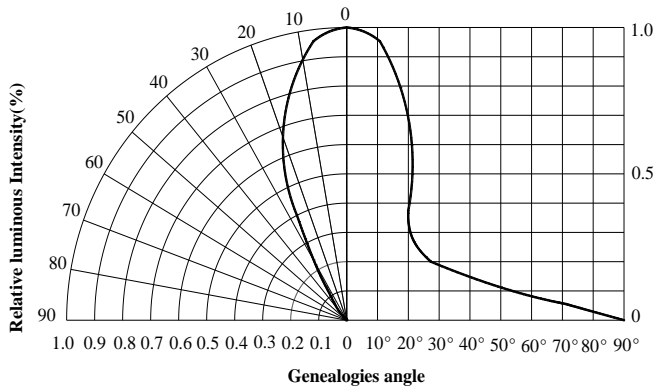

Forward Voltage

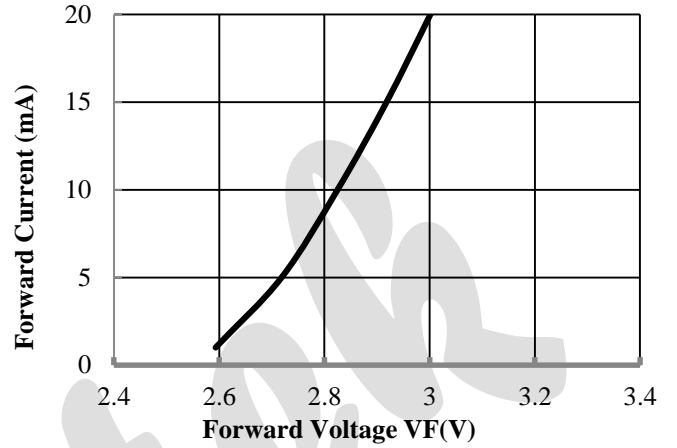

Relative Luminous Intensity

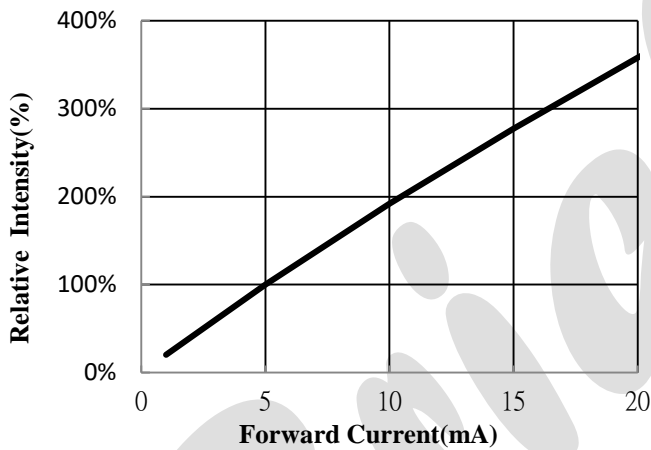

Relative Luminous Intensity vs. Temperature

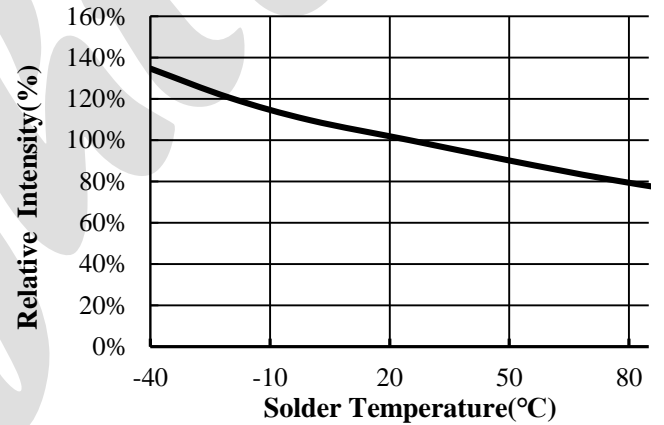

Permissible Forward Current

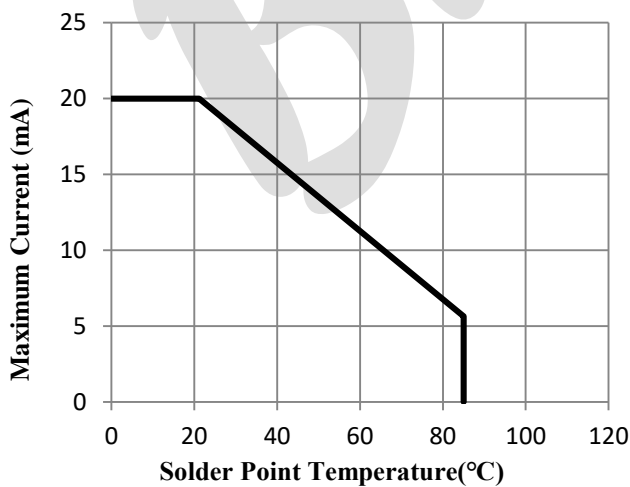

Relative Spectral Emission

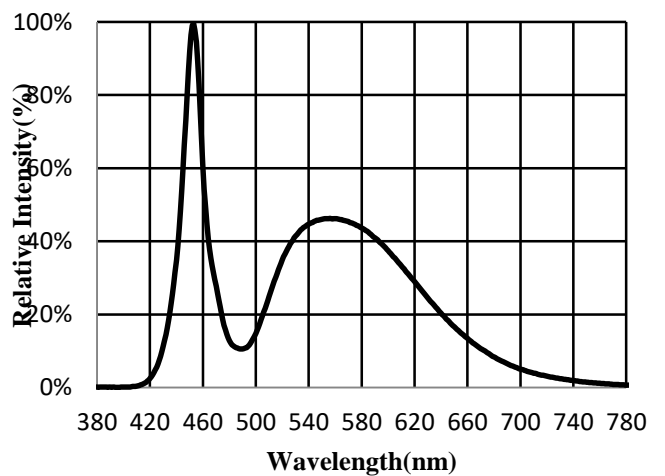

Reflow Soldering Profile

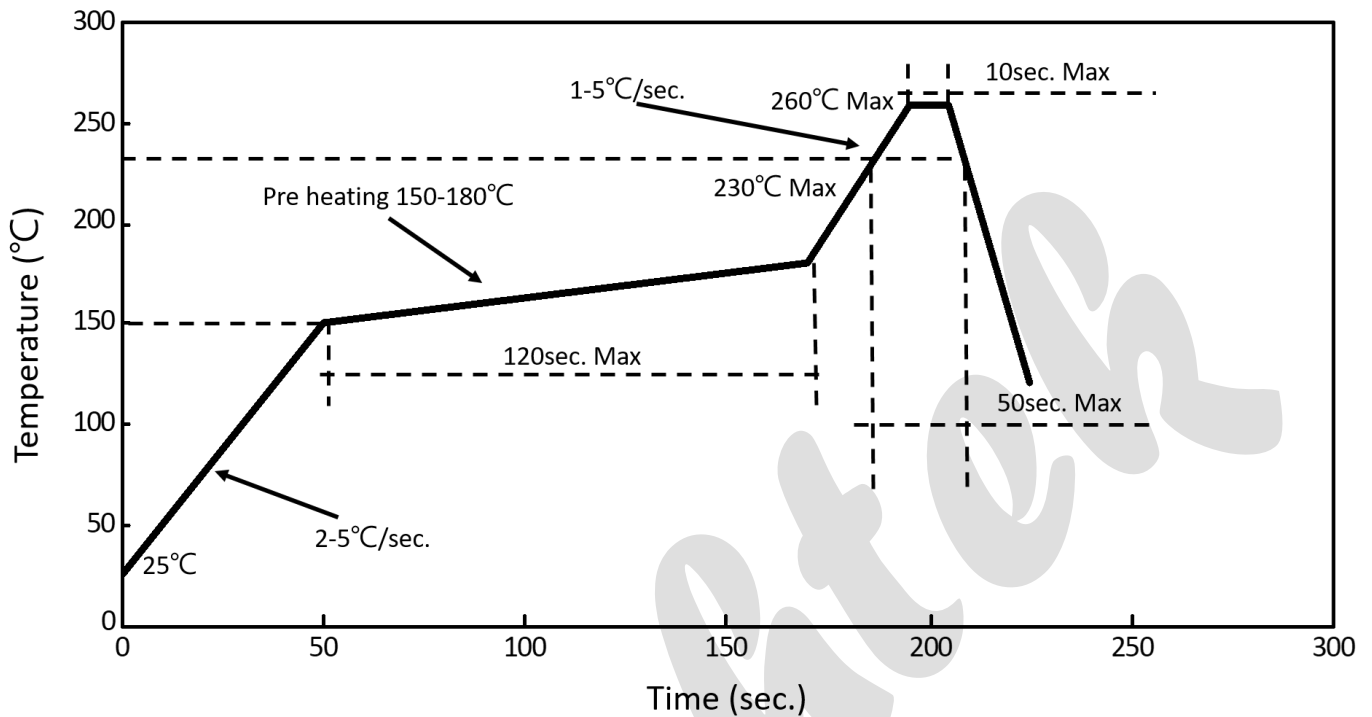

1. We recommend the reflow temperature 240°C ($\pm 5^\circ\text{C}$).the maximum soldering temperature should be limited to 260°C.
2. Do not stress the silicone resin while it is exposed to high temperature.
3. The reflow process should not exceed 3 times.

Test Circuit and Handling Precautions

1. Test circuit

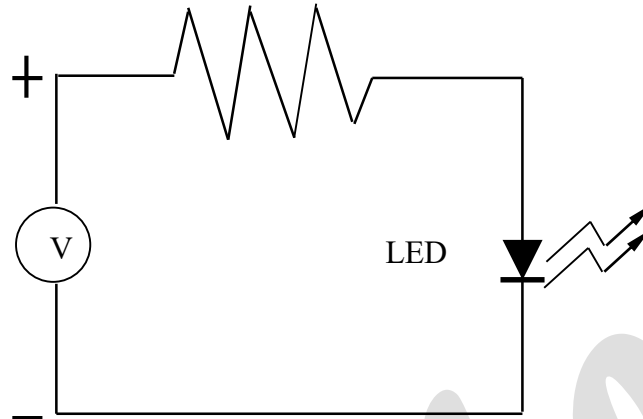

2. Handling precautions

2.1 Over-current-proof

Customer must apply resistors for protection; otherwise slight voltage shift will cause big current change (Burn out will happen).

2.2 Storage

① It is recommended to store the products in the following conditions:

- Humidity: 60% R.H. Max.
- Temperature : $5^{\circ}\text{C} \sim 30^{\circ}\text{C}$ ($41^{\circ}\text{F} \sim 86^{\circ}\text{F}$)

② Shelf life in sealed bag: 12 month at $< 5^{\circ}\text{C} \sim 30^{\circ}\text{C}$ and $< 60\%$ R.H. after the package is Opened, the products should be used within 1 week or they should be keeping to storage at $\leq 20\%$ R.H. with zip-lock sealed.

2.3 Baking

Suggest packing open after 1 week, before use baking products, conditions as follows:

- ① $60 \pm 3^{\circ}\text{C}$ X 6hrs and $< 5\%$ RH, for reel
- ② $125 \pm 3^{\circ}\text{C}$ X 2hrs, for single LED

It shall be normal to see slight color fading of carrier (light yellow) after baking in process.

SA0603W50BBZ2

Tapping

1. Dimensions of Tape (Unit: mm)

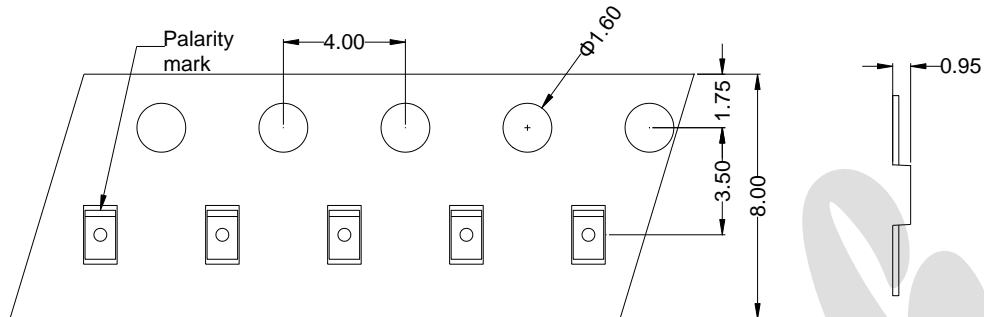

2. Arrangement of Tape

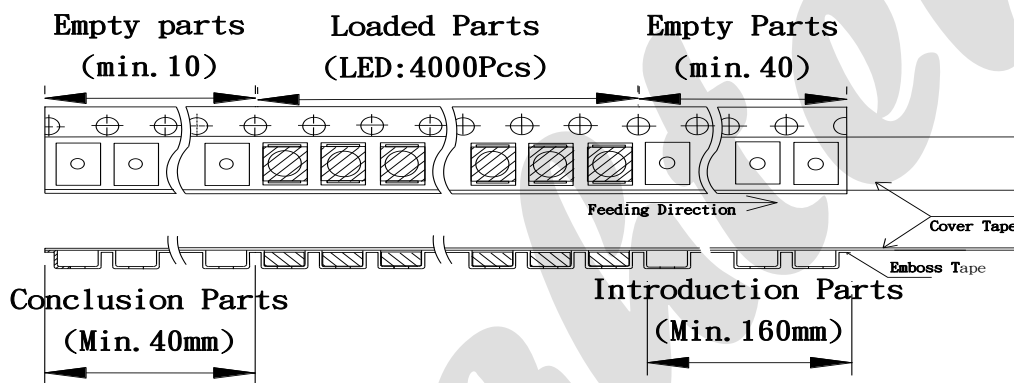

3. Dimensions of Reel (Unit: mm)



Notes:

1. Empty component pockets are sealed with top cover tape
2. The max loss number of SMD is 2pcs
3. The cathode is oriented towards the tape sprocket hole in accordance with ANSI/EIA RS-481 specifications
4. 4,000pcs per reel
5. The remainder packing in multiples of 500pcs.

SA0603W50BBZ2

Packing

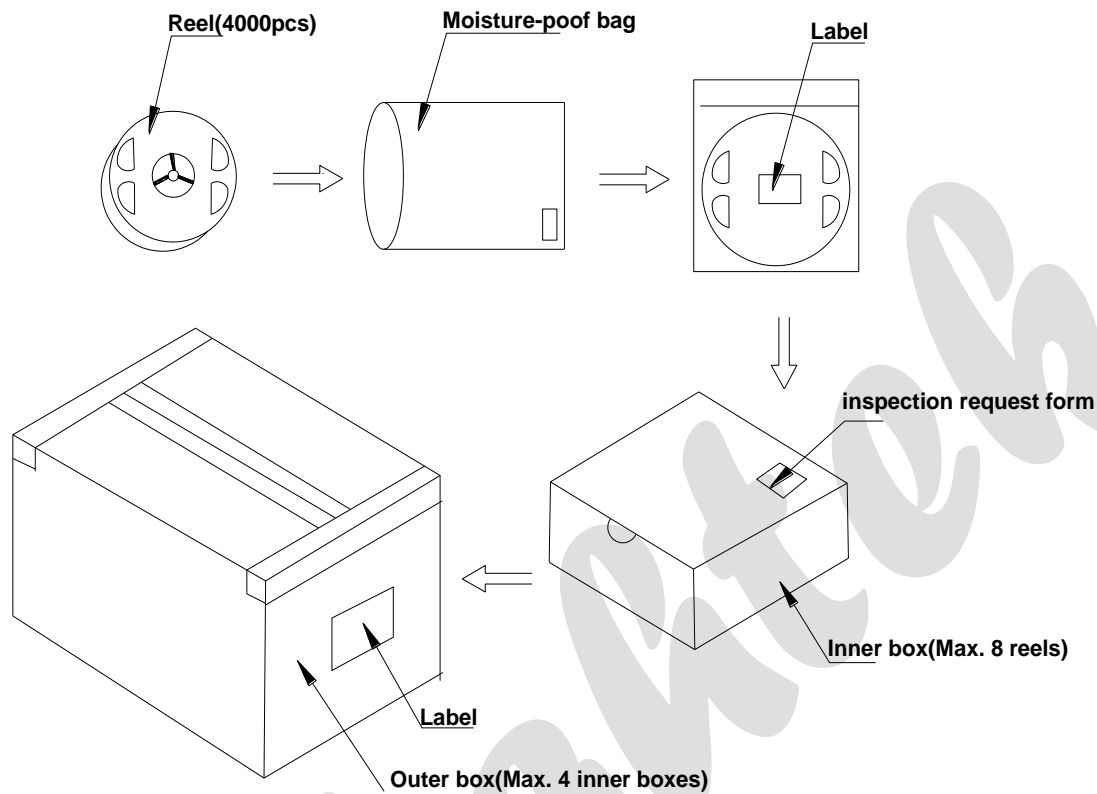

Reeled product (max.4,000) is packed in a sealed moisture-proof bag. eight bags are packed in an inner box (size: about 260 X 230 X 100 mm) and four inner boxes are in an outer box (size: about 480 X 275 X 215 mm). On the label of moisture-pooof bag, there should be the information of Part No., Lot No. and quantity number; also the total quantity number should be on inspection request form on outer box.

Precautions

1. Abnormal situation caused by improper setting of collet

To choose the right collet is the key issue in improving the product's quality. LED is different from other electronic components, which is not only about electrical output but also for optical output. This characteristic made LED more fragile in the process of SMT. If the collet's lowering down height is not well set, it will bring damage to the gold wire at the time of collet's picking up and loading which will cause the LED fail to light up, light up now and then or other quality problems.

2. How to choose the collet

During SMT, please choose the collet that has larger outer diameter than the lighting area of lens, in case that improper position of collet will damage the gold wire inside the LED. Different collets fit for different products, please refer to the following pictures cross out.

Outer diameter of collet should be larger than the lighting area

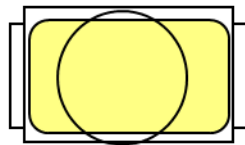

Picture 1 (✓)

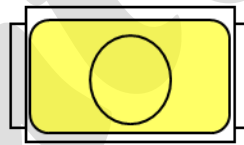

Picture 2 (X)

3. Other points for attention

- No pressure should be exerted to the epoxy shell of the SMD under high temperature.
- Do not scratch or wipe the lens since the lens and gold wire inside are rather fragile and cross out easy to break.
- CLED should be used as soon as possible when being taken out of the original package, and should be stored in anti-moisture and anti-ESD package.

4. This usage and handling instruction is only for your reference.